

Installation Instructions

Fanir Rd: S-FN-_/RD/CTS/_



Unit 8 Gemini 8 Business Park
Charon Way
Apollo Park
Warrington
WA5 7AE

www.spectre-lighting.com

Safety Precautions.

- Power Isolation: Always disconnect the power supply before installing, removing, or servicing the product to prevent electric shock, injury, or damage.
- Qualified Installation: Luminaires should be installed by a certified electrician in accordance with current local wiring regulations.
- Damaged Components: Replace any broken or faulty parts promptly. Spectre Lighting cannot be held liable for issues resulting from poor installation practices.
- Ambient Temperature: Ensure the room temperature does not exceed 25°C during operation.
- Power Supply Compatibility: These products are intended for use with a mains supply of 230–240V~ at 50/60Hz.
- Inrush Current Consideration: You may need to upgrade your MCBs to accommodate higher inrush currents.
- Insulation Testing: Do not perform insulation resistance tests while the product is connected to the circuit.
- Preparation: Review all instructions thoroughly and confirm you have the necessary tools and accessories for proper installation.

5yrs
Warranty

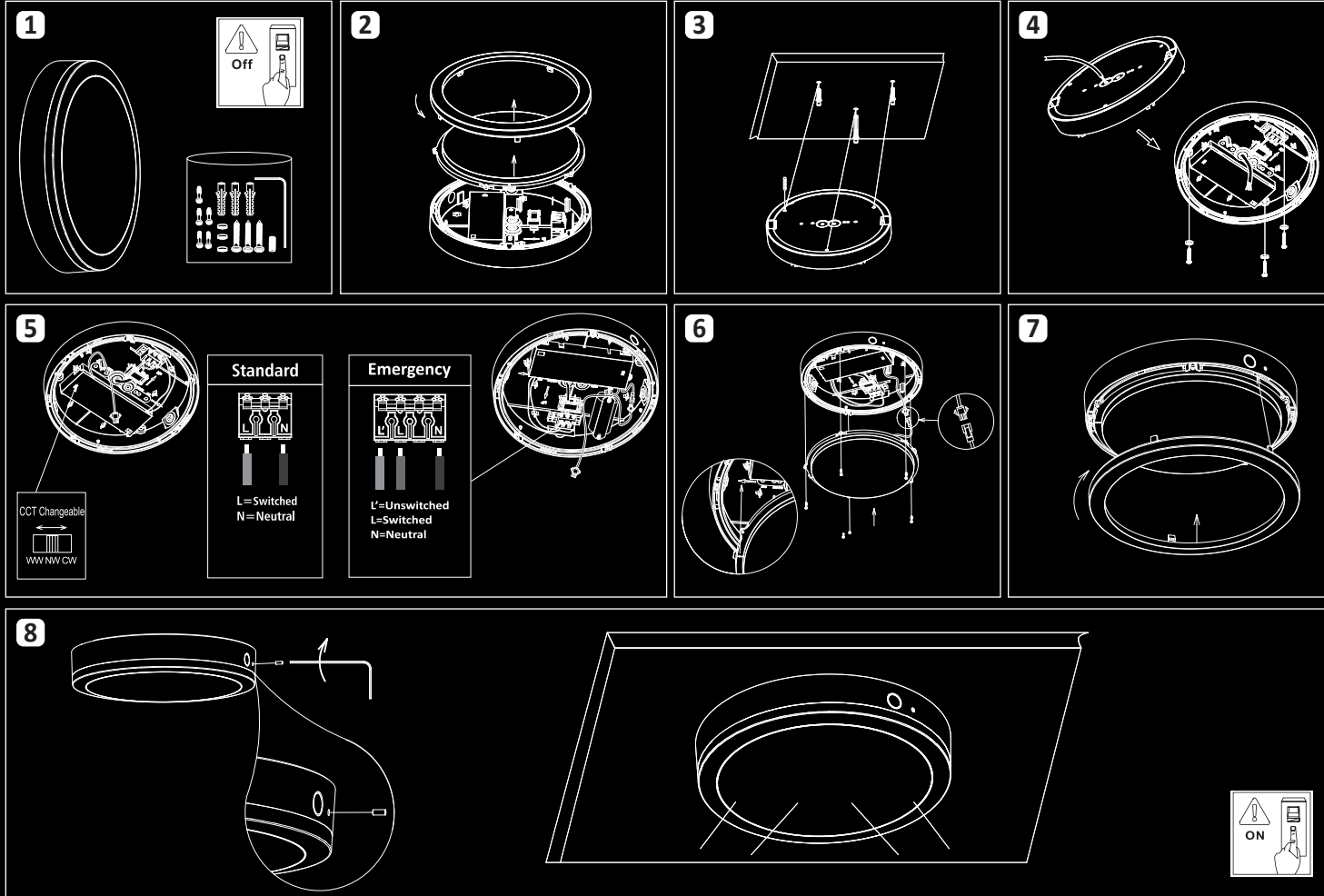

Installation Instructions

- Fig 1. Ensure power supply is isolated before proceeding with installation.
- Fig 2. Remove outer bezel. Twist diffuser anticlockwise and remove front assembly and disconnect via male / female connector.
- Fig 3. Locate desired surface for installation. Mark appropriate fixing hole positions on wall / ceiling, check location of buried cables, pipes, and other building services before drilling.
- Fig 4. Feed through supply cable into base via cable grommet. Applying adequate sealant to maintain IP65 rating. Fix to surface.
- Fig 5. Set product to desired CCT output using dip switches located on the LED driver. Connect supply cable to luminaire into push fit terminations ensuring correct polarity is observed. These products are intended for use with a mains supply of 110–240V~ at 50/60Hz.
- Fig 6. Reattach front assembly and reconnect male and female connectors. Aligned arrows detailed on base and diffuser.
- Fig 7. Secure bezel into position using locking screw.
- Fig 8. Reinstated power supply.

IP65

CE

UK
CA

RoHS
Comp Liant



Installation Instructions

Fanir Rd: S-FN-_/RD/CTS/_



Unit 8 Gemini 8 Business Park
Charon Way
Apollo Park
Warrington
WA5 7AE

www.spectre-lighting.com

Specification

S-FN-12/RD/CTS/_

- Voltage Range—220-240V 50/60Hz
- CCT—3000K / 4000K / 6500K
- CRI80
- IP65 / IK10
- 12W
- 1,250-1,400lm / 110lm/w
- Temp Range— -20°C -45 °C

Specification

S-FN-12/RD/CTS/EM3_

- Voltage Range—220-240V 50/60Hz
- CCT—3000K / 4000K / 6500K
- CRI80
- IP65 / IK10
- 12W
- 1,250-1,400lm / 110lm/w
- Temp Range— 0°C -45 °C

Specification

S-FN-18/RD/CTS/_

- Voltage Range—220-240V 50/60Hz
- CCT—3000K / 4000K / 6500K
- CRI80
- IP65 / IK10
- 18W
- 1,750-1,950lm / 110lm/w
- Temp Range— -20°C -45 °C

Specification

S-FN-18/RD/CTS/EM3_

- Voltage Range—220-240V 50/60Hz
- CCT—3000K / 4000K / 6500K
- CRI80
- IP65 / IK10
- 18W
- 1,750-1,950lm / 110lm/w
- Temp Range— 0°C -45 °C

Specification

S-FN-25/RD/CTS/_

- Voltage Range—220-240V 50/60Hz
- CCT—3000K / 4000K / 6500K
- CRI80
- IP65 / IK10
- 25W
- 2,300-2,550lm / 110lm/w
- Temp Range— -20°C -45 °C

Dimensions

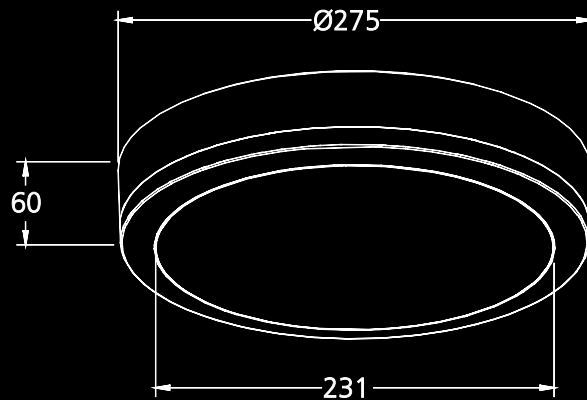

Replaceable control gear
by a professional

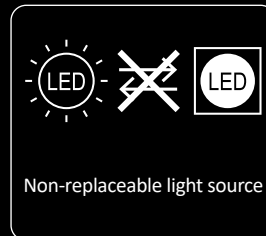

Non-replaceable light source

The light source of this luminaire is not replaceable, when the light source reaches its end of life the luminaire shall be replaced, utilising the existing driver



Important Disposal Information for Waste Electrical & Electronic Equipment (WEEE)

Please be aware that Waste Electrical and Electronic Equipment (WEEE), identified by the crossed-out wheelee bin symbol, must NOT be disposed of with regular household waste.

We encourage you to support reuse, recycling, and responsible recovery by returning this product—once it reaches the end of its life—to an appropriate collection point. This may include a designated waste equipment centre, a civic amenity site, or the retailer where you originally purchased the item or are buying a replacement.

Improper disposal of this equipment may release substances that are harmful to both human health and the environment. To prevent this, it is essential that WEEE is separated from general waste and processed through approved recycling channels.

The crossed-out wheelee bin symbol serves as a reminder that this product requires special handling in accordance with local WEEE regulations.

IP65

CE UK
CA

RoHS
Comp Liant



