

Installation Instructions

ForgeLight NCF: S-FL-X/CTS



Spectre Lighting
 Unit 8, Gemini 8 Business Park
 Charon Way
 Apollo Park
 Warrington
 WA5 7AE
www.spectre-lighting.com

Safety Precautions

- Power Isolation: Always disconnect the power supply before installing, removing, or servicing the product to prevent electric shock, injury, or damage.
- Qualified Installation: Luminaires should be installed by a certified electrician in accordance with current local wiring regulations.
- Damaged Components: Replace any broken or faulty parts promptly. Spectre Lighting cannot be held liable for issues resulting from poor installation practices.
- Ambient Temperature: Ensure the room temperature does not exceed 25°C during operation.
- Power Supply Compatibility: These products are intended for use with a mains supply of 230–240V~ at 50/60Hz.
- Inrush Current Consideration: You may need to upgrade your MCBs to accommodate higher inrush currents.
- Insulation Testing: Do not perform insulation resistance tests while the product is connected to the circuit.
- Preparation: Review all instructions thoroughly and confirm you have the necessary tools and accessories for proper installation.

5yrs
 Warranty

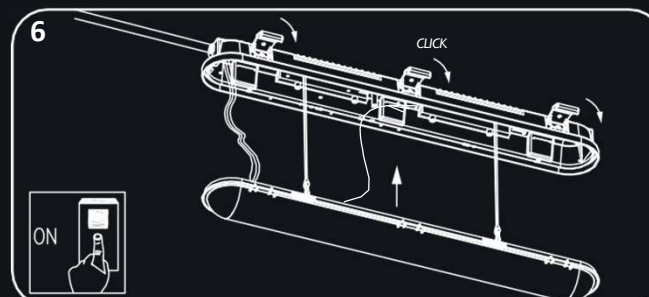
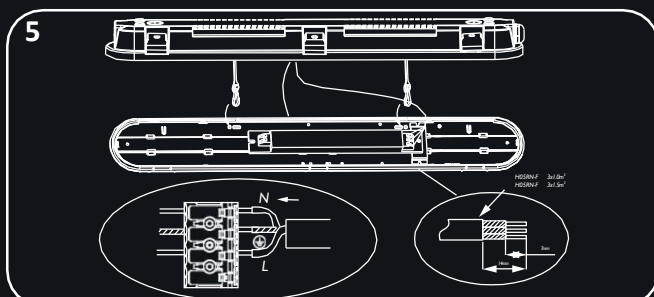
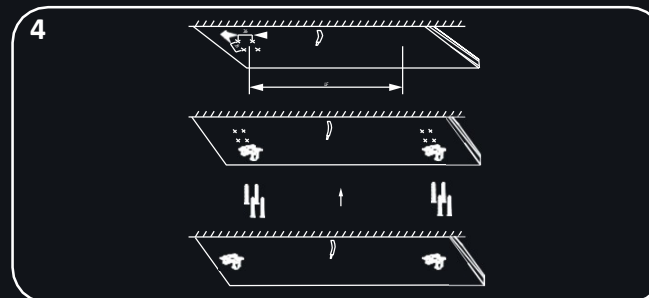
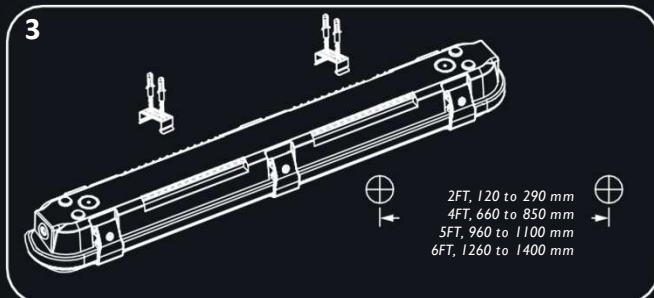
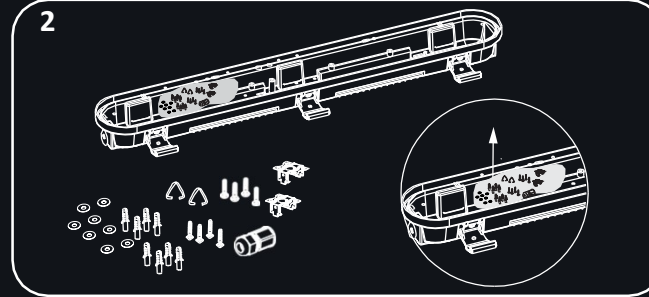
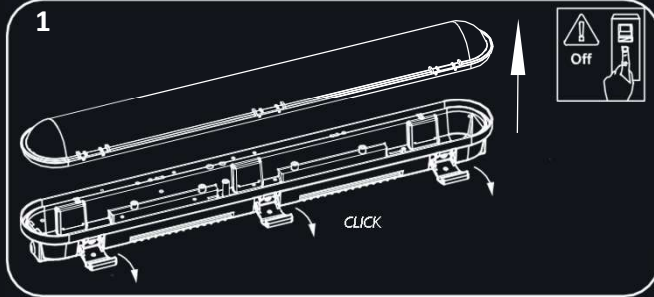

Installation Instructions

General

Fig 1. Ensure power supply is isolated before proceeding with installation. Unclip and securing installation clips, remove and disconnect LED diffuser / gear tray assembly from base.

Fig 2. Remove accessories and select based on required installation method.

Fig 3. Take note of desired surface / suspension mounting locations and ensure this is within the product's mounting measurement range.

Fig 4. If surface mounting, mark and fix surface mounting brackets to installation surface using brackets and fixings supplied. Please Note – Do not drill the base for mounting purposes, as this may compromise the IP rating and warranty.

Fig 5. Feed supply cable into base using IP66 compression gland. Connect supply cables to main terminals ensuring correct polarity is observed. These products are intended for use with a mains supply of 220–240V~ at 50/60Hz.

Fig 6. Re-install LED diffuser / gear tray assembly, connecting the male / female connectors.

Select desired CCT output and wattage via inbuilt switches on gear tray. Locate and clip all installation clips into position ensuring correct / adequate compression. Reinstall power supply.

IP66



Installation Instructions

ForgeLight NCF: S-FL-X/CTS



Spectre Lighting
 Unit 8, Gemini 8 Business Park
 Charon Way
 Apollo Park
 Warrington
 WA5 7AE
www.spectre-lighting.com

Safety Precautions

- Power Isolation: Always disconnect the power supply before installing, removing, or servicing the product to prevent electric shock, injury, or damage.
- Qualified Installation: Luminaires should be installed by a certified electrician in accordance with current local wiring regulations.
- Damaged Components: Replace any broken or faulty parts promptly. Spectre Lighting cannot be held liable for issues resulting from poor installation practices.
- Ambient Temperature: Ensure the room temperature does not exceed 25°C during operation.
- Power Supply Compatibility: These products are intended for use with a mains supply of 230–240V~ at 50/60Hz.
- Inrush Current Consideration: You may need to upgrade your MCBs to accommodate higher inrush currents.
- Insulation Testing: Do not perform insulation resistance tests while the product is connected to the circuit.
- Preparation: Review all instructions thoroughly and confirm you have the necessary tools and accessories for proper installation.

5yrs
 Warranty

Plug and Play: Wiring Diagrams

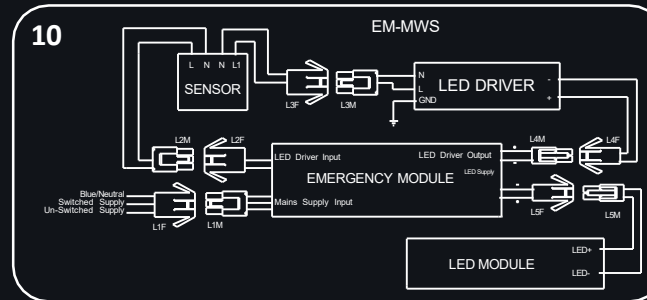
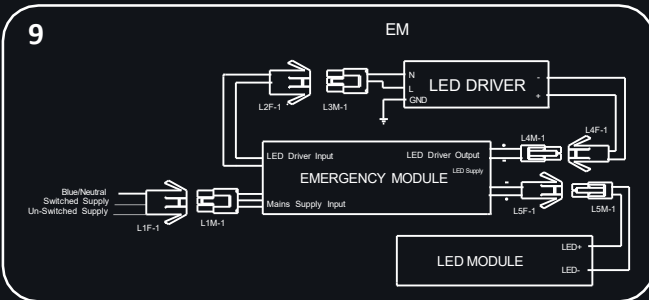
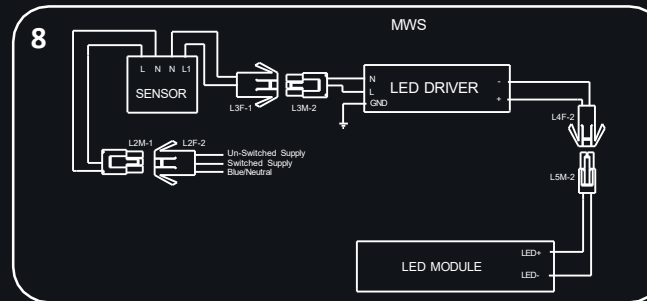
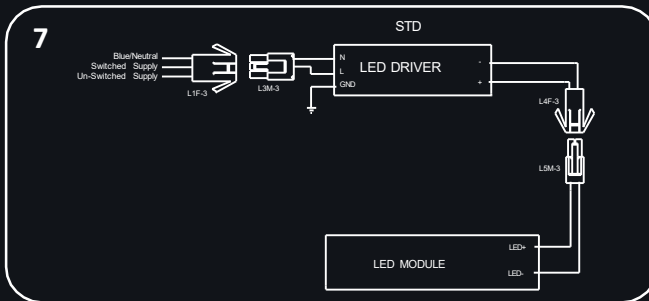

Installation Instructions

Module Conversion

Fig 7. Standard Circuit.

Fig 8. Microwave sensor module diagram.

Fig 9. Emergency module diagram.

Fig 10. Microwave and Emergency Module Diagram.

*The luminaire supports the above configurations.

Please refer to the corresponding diagram for your required function.

IP66



Installation Instructions

ForgeLight NCF: S-FL-X/CTS



Spectre Lighting
 Unit 8, Gemini 8 Business Park
 Charon Way
 Apollo Park
 Warrington
 WA5 7AE
www.spectre-lighting.com

Specification

S-FL-2/CTS

- Voltage Range – 220-240V 50/60Hz
- CCT – 3000K / 4000K / 6000K
- IP66 / IK10
- CRI80
- 12W / 15W / 17W / 20W - 160Lm/W
- 1,920lm / 2,400lm / 2,720lm / 3,200lm
- Temp Range -10 – 40 °C

S-FL-4/CTS

- Voltage Range – 220-240V 50/60Hz
- CCT – 3000K / 4000K / 6000K
- IP66 / IK10
- CRI80
- 21W / 26W / 32W / 36W - 160Lm/W
- 3,360lm / 4,160lm / 5,120lm / 5,760lm
- Temp Range -10 – 40 °C

S-FL-5/CTS

- Voltage Range – 220-240V 50/60Hz
- CCT – 3000K / 4000K / 6000K
- IP66 / IK10
- CRI80
- 28W / 34W / 42W / 48W - 160Lm/W
- 4,480lm / 5,440lm / 6,720lm / 7,680lm
- Temp Range -10 – 40 °C

S-FL-6/CTS

- Voltage Range – 220-240V 50/60Hz
- CCT – 3000K / 4000K / 6000K
- IP66 / IK10
- CRI80
- 33W / 40W / 48W / 56W - 160Lm/W
- 5,280lm / 6,400lm / 7,680lm / 8,960lm
- Temp Range -10 – 40 °C

Dimensions

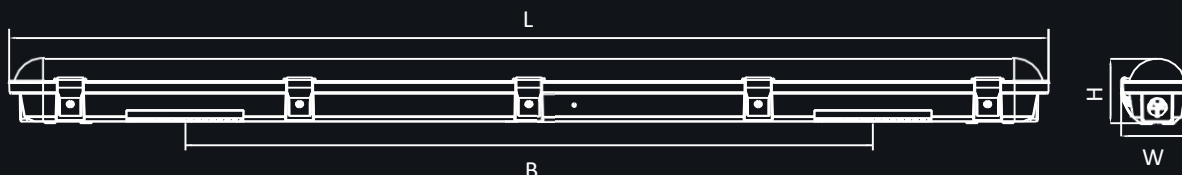

Model no.	Dimension sizes(mm)			Installation size(mm)
	L	W	H	B
S-FL-2/CTS	550	80	71	220
S-FL-4/CTS	1150	80	71	778
S-FL-5/CTS	1450	80	71	1061
S-FL-6/CTS	1750	80	71	1361



▲ Important Disposal Information for Waste Electrical & Electronic Equipment (WEEE)

Please be aware that Waste Electrical and Electronic Equipment (WEEE), identified by the crossed-out wheellie bin symbol, must NOT be disposed of with regular household waste.

We encourage you to support reuse, recycling, and responsible recovery by returning this product—once it reaches the end of its life—to an appropriate collection point. This may include a designated waste equipment centre, a civic amenity site, or the retailer where you originally purchased the item or are buying a replacement.

Improper disposal of this equipment may release substances that are harmful to both human health and the environment. To prevent this, it is essential that WEEE is separated from general waste and processed through approved recycling channels.

The crossed-out wheellie bin symbol serves as a reminder that this product requires special handling in accordance with local WEEE regulations.

IP66



UK
CA

RoHS



Microwave Sensor



Spectre Lighting
 Unit 8, Gemini 8 Business Park
 Charon Way
 Apollo Park
 Warrington
 WA5 7AE
www.spectre-lighting.com

Dimension Diagram

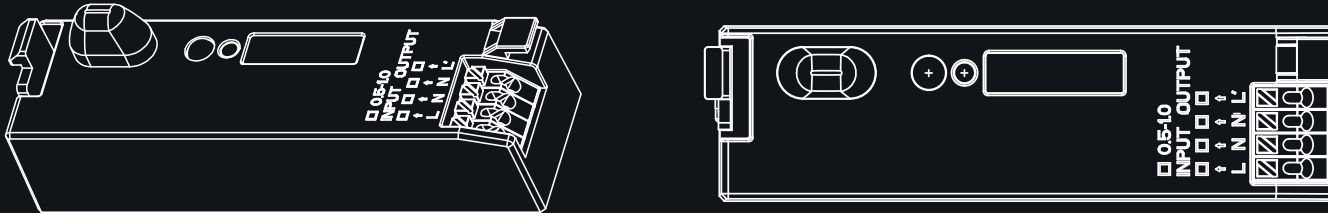

DIP Switch Setting



Detection Area

1	2		Detection Radius
ON	ON	100%	Around 5 meters
-	ON	75%	Around 4 meters
ON	-	50%	Around 2.5 meters
-	-	25%	Around 1.5 meters

Hold Time

3	4	5	
ON	ON	ON	5s
-	ON	ON	30s
ON	-	ON	90s
-	-	ON	5min
ON	ON	-	20min
-	-	-	30min

Daylight Sensor

3	4	5	
ON	ON	ON	5s
-	ON	ON	30s
ON	-	ON	90s
-	-	ON	5min
ON	ON	-	20min

